

As per Board of Zoning Appeals meeting 5-7-74
This Permit of NAPOLEON IS O.K.

BUILDING CONSTRUCTION PERMIT

Owner Name
Address
Builder Name
Address Tel.

Lot Information:
Street No.
Lot Subdivision
Lot Dimensions Lot Area Sq. Ft.
Yard Set Back: Front Rear
Side Side

Sidewalk required in accordance with Ordinance No.

Building Information:

Residence Commercial Industrial
Single Double Multiple New Construction Addition Remodel
Size: Length Width No. of Stories
Floor Area: 1st Floor 2nd Floor 3rd Floor Basement

Unfinished Attic Garage
Foundation: Piers Full Basement Part Basement
Concrete Block Brick Other
Walls: Frame Block Brick
Electrical Outlets: 120v 240v
Plumbing: Fixtures Traps Vents Heating Air Conditioning

Date Applicant Signature
Date 2-23-74

Inspection Record:
Work Started Foundations
Set Back, Side Lines Plumbing (Rough In) OK 6-18-74 And Air Conditioning
Excavation 5-13-74 Erecting Frame Roof

Footings 15 yd³ 5-13-74 Electrical Work OK 7-25-74 by Bob Meyers P.W.P.
Comments: Informed Bauman attic access door required on both sides 7/24/74

Permit No.
Issued
By Building Inspector

Estimated Cost	Fees	Base	Plus	Total
Construction				
Basement				
Detached Garage				
Plumbing				
Electrical				
Heating				
Air Conditioning				
Water Tap				
Sewer Tap				
Temporary Electric				
Total				

Certificate of Occupancy Issued
Inspector
Pink - Engineer

CERTIFICATE OF OCCUPANCY

(140 Northcrest St.)

September 19, 1974

Date 30-74

Final inspection of building construction authorized by Permit Number _____ has been made. Construction is completed substantially in conformity with the approved plans and permission is hereby granted to occupy such building in compliance with such legal use and occupancy as may be authorized under the provisions of the zoning ordinance of the City of Napoleon.

Thomas W. Lenora

Building Inspector

Name: _____ Size of Tap 6" Date 5-20-74
 Street Northeast Dr. Size and Kind of Sewer Main; 10" conc.
 Old No. _____ Location of Sewer _____
 New No. _____ Depth of Sewer 3'-6"
 Crossover/L _____ Distance to Curb Stop _____
 Remarks: _____

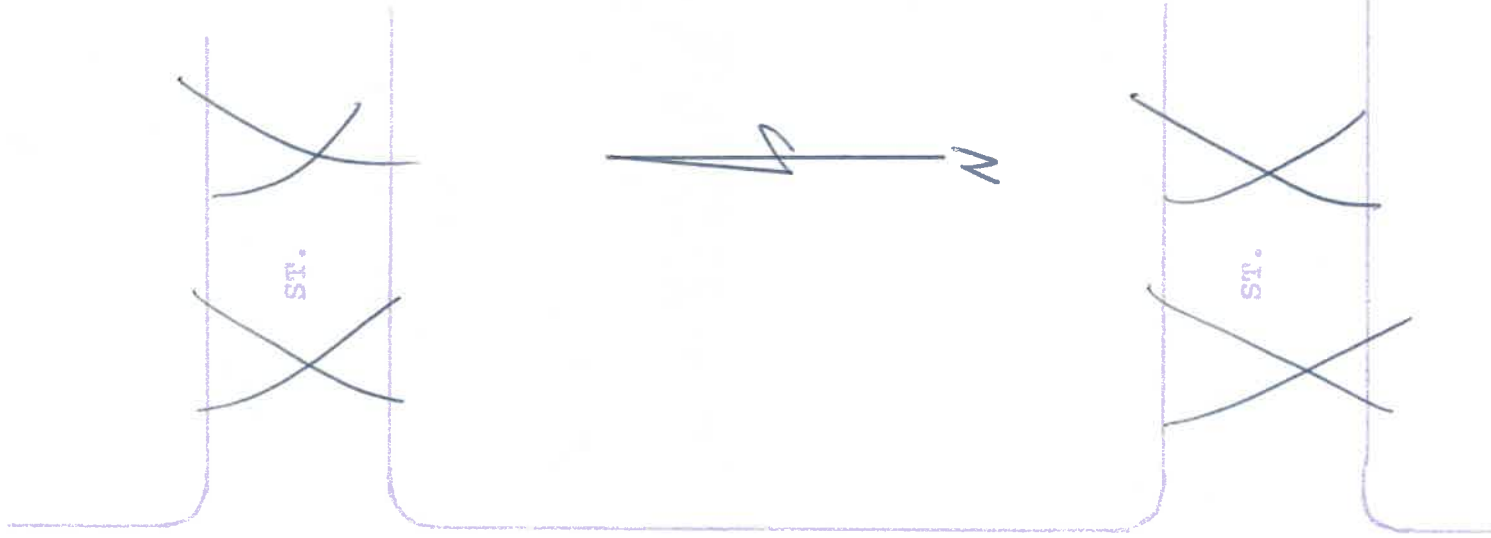
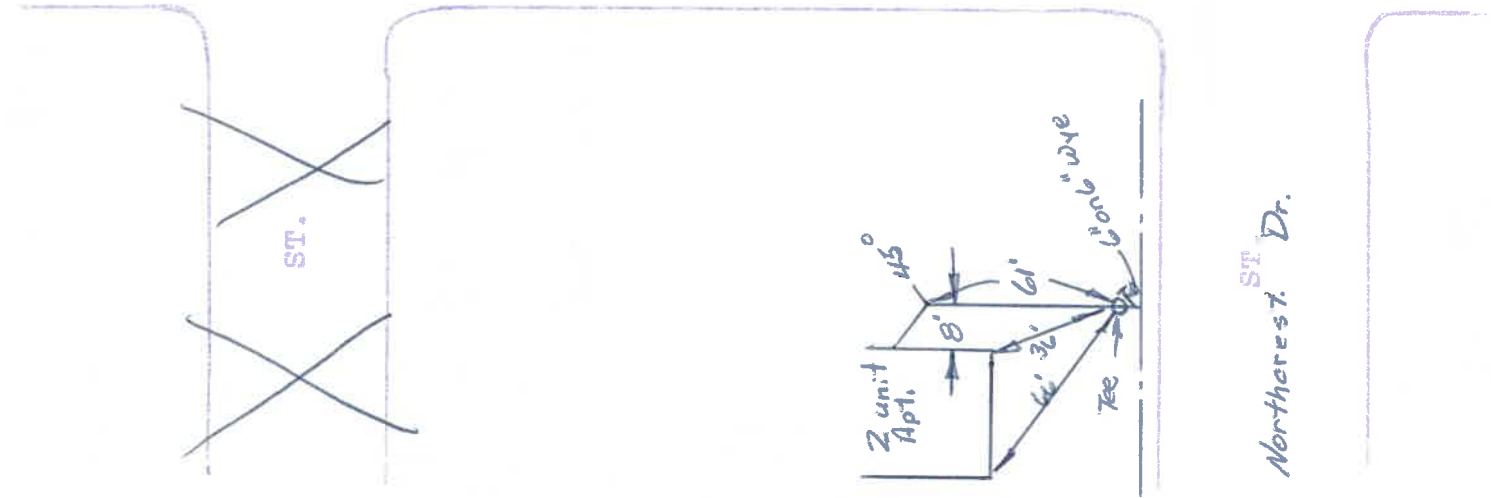

Oakwood Ave
ST.

ST. Northeast Dr.

APPLICATION FOR PERMIT TO TAP SEWER

No. 645 Date 4-23 1974

Name Bauman Stockyard
Address Box 150 Napoleon

LOCATION OF CONNECTION

Street and Number 140 Northwest
Lot No. 45 Addition Northwest

Date work will start _____ (All work must be inspected)

Work will be done by _____

I certify that the sewer will be used only as indicated and no other drainage will be connected.

Applicant _____

Date 4-23-74 Address _____

Permit Fee 60⁰⁰ R.W. Schweinhagen J.C.
Certification by City Clerk

Work Inspected 5-20-74, pressure tested OK RHB.

Work Completed _____

Per 4-24-74
Remarks Bldg permit # 30